

# ASSEMBLY INSTRUCTIONS

## ALASKA FULL BED

Ref. 2141 - Whitewash

Ref. 2142 - Mahogany





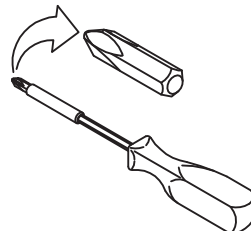
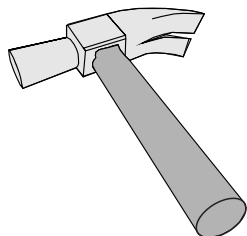
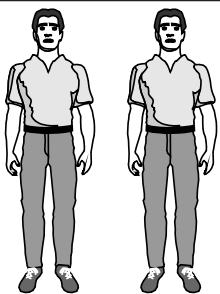
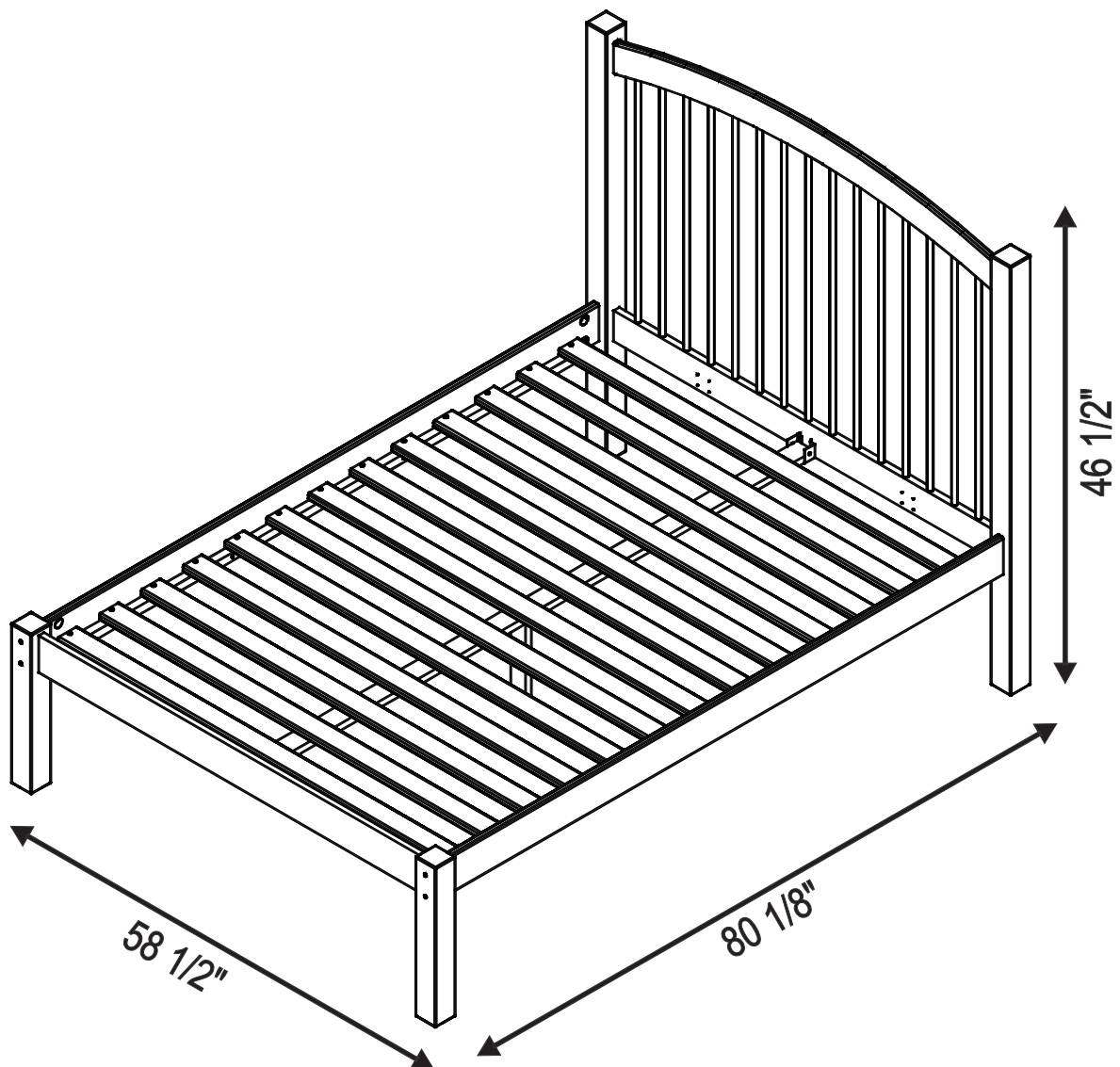

Ref. 2144 - Honey Pine

Ref. 2146 - Java

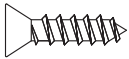
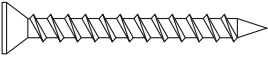

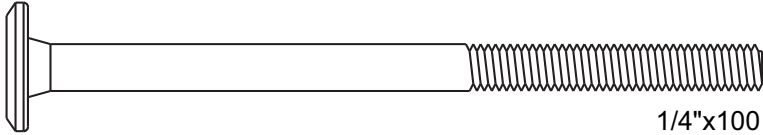
55 min

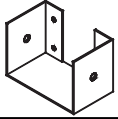

HARDWARE IS SHOWN IN ACTUAL SIZE

A2	 4,0x50	02
A5	 3,5x16	12
A10	 3,5x30	26
B5	 1/4"	08
B12	 1/4"x100	08
C3	 10x40	04
D11		02
G3		01
G4	 space block	02



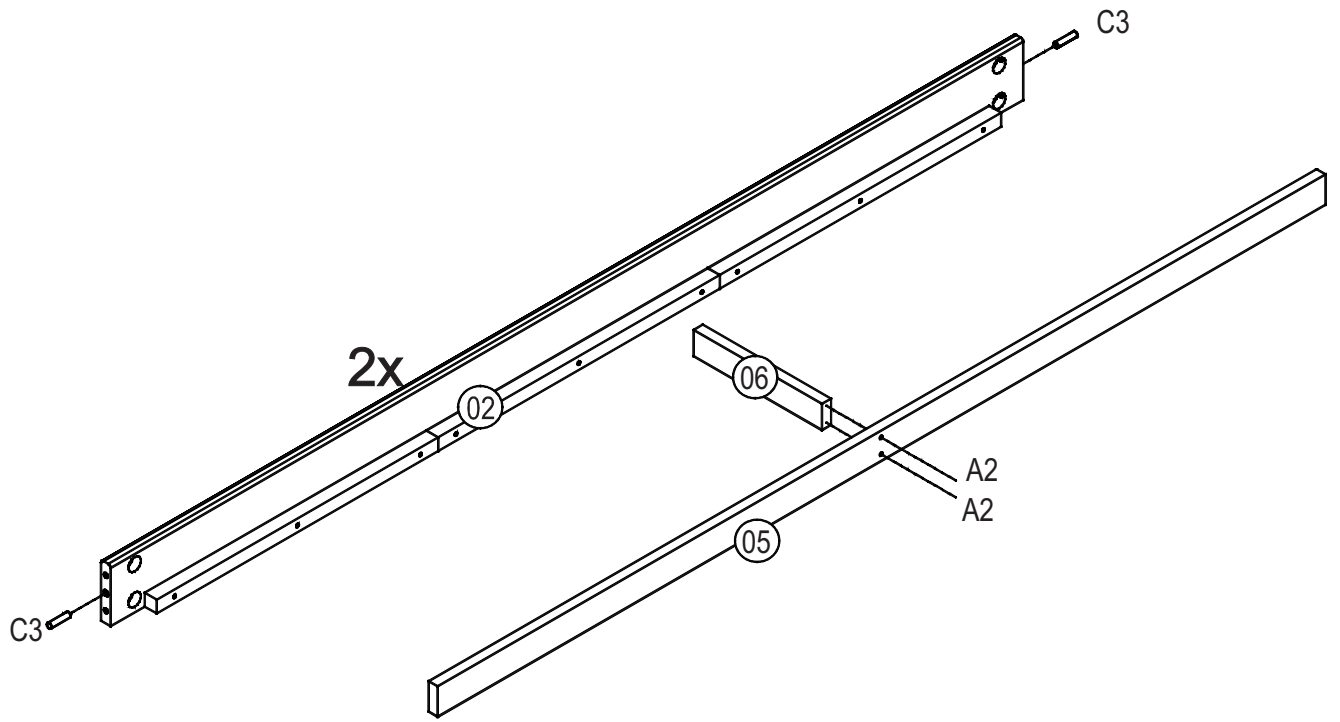

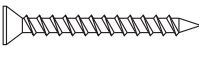
01)

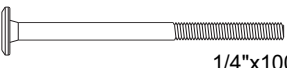

A2	 4,0x50	02	C3	 10x40	04
----	---	----	----	--	----

02)

B5	 1/4"	08
B12	 1/4"x100	08
G3		01

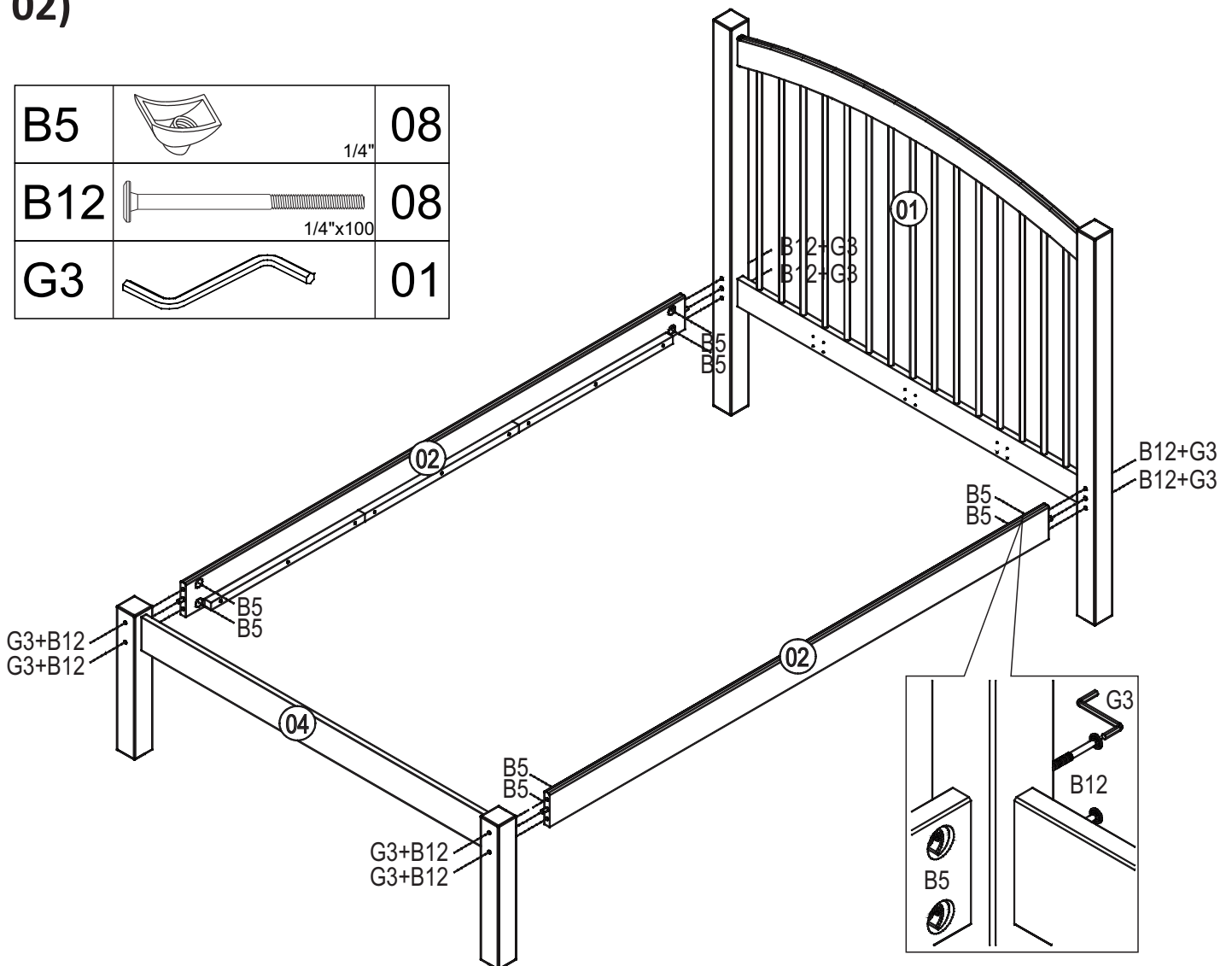

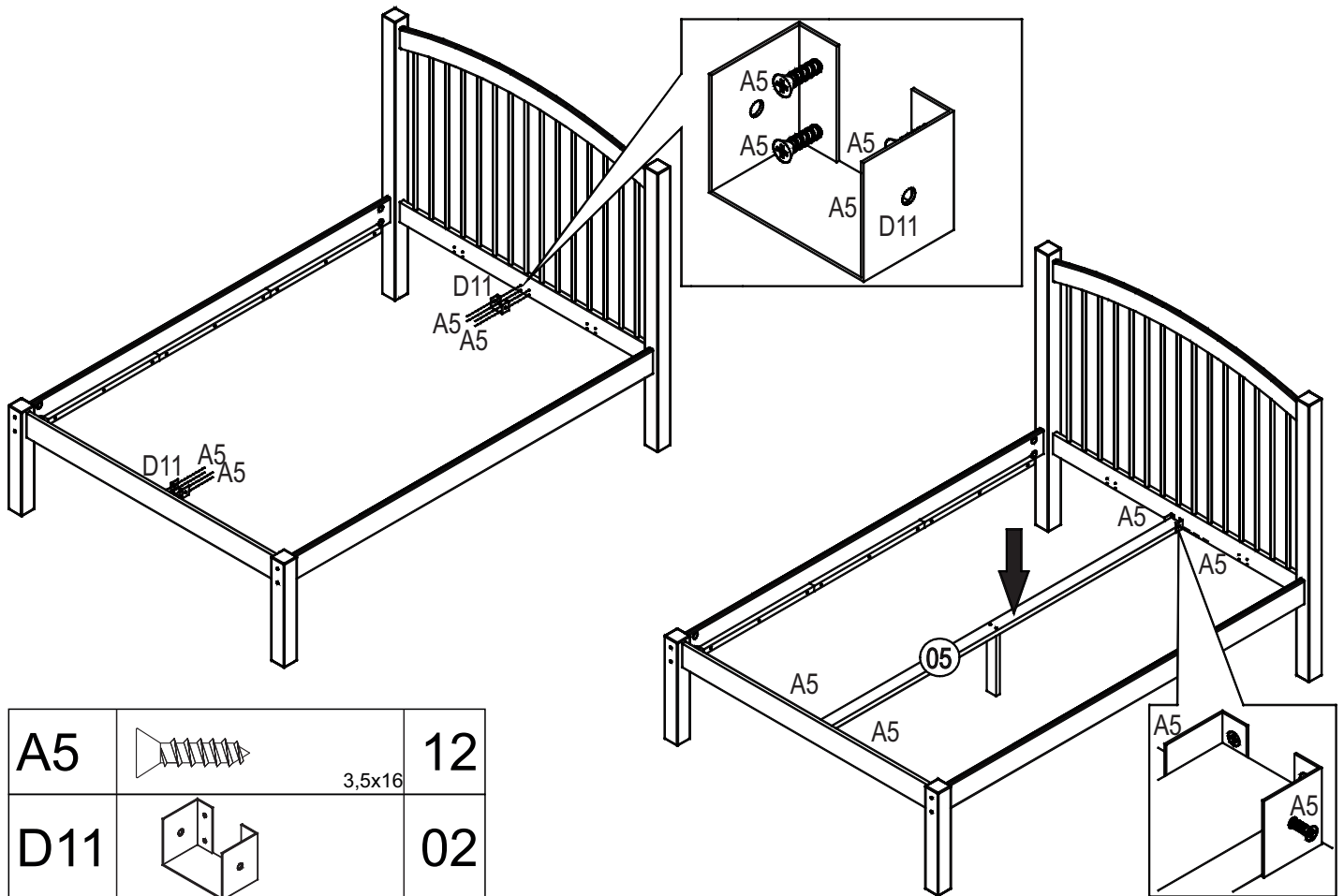

### 03) OPTION 01 - use this option if you are not using the optional trundle

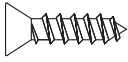
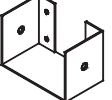

A5		3,5x16	12
D11			02

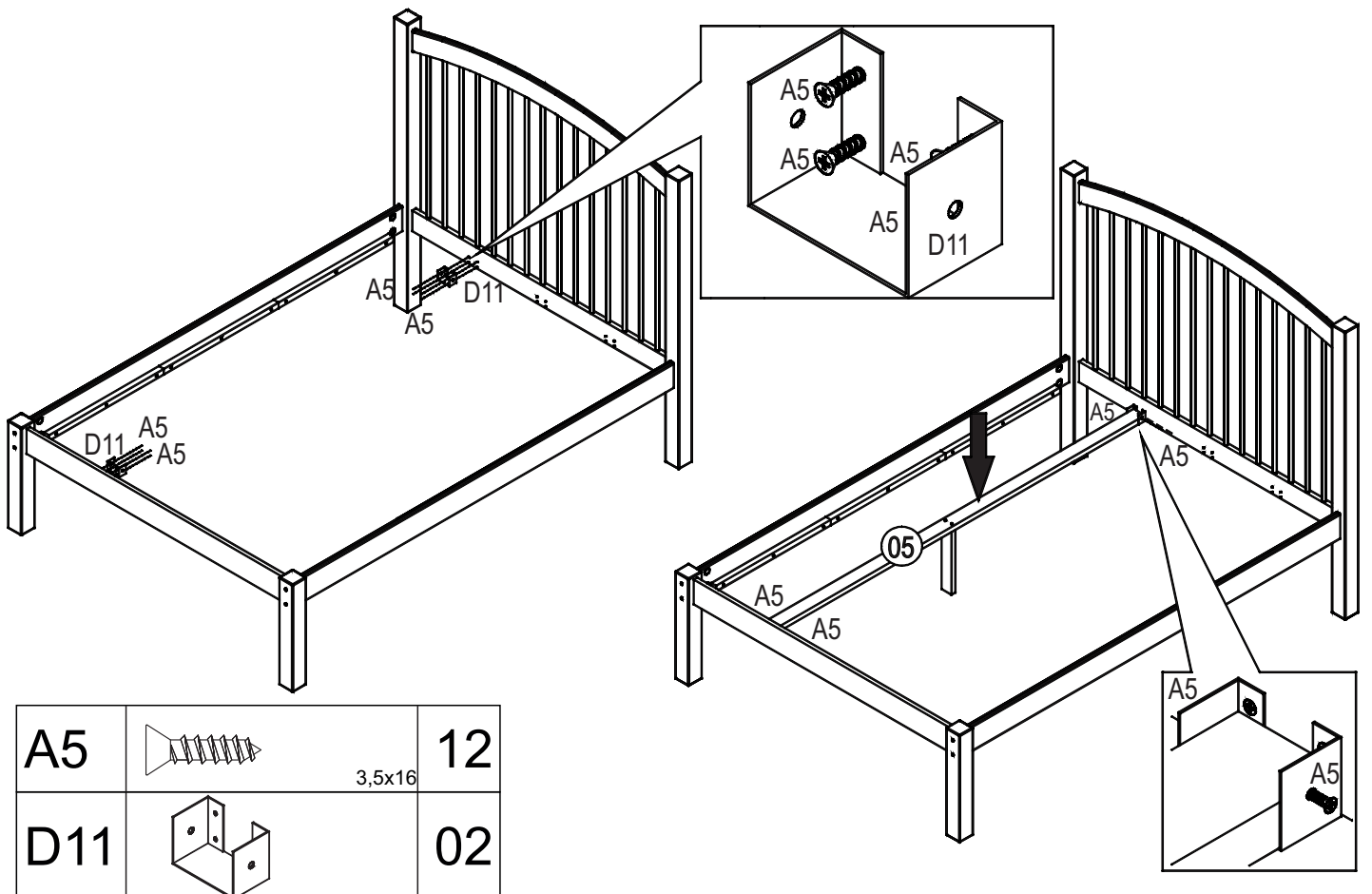
### 03) OPTION 02 - use this option if you have the optional trundle

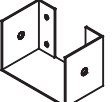

A5		3,5x16	12
D11			02

04)

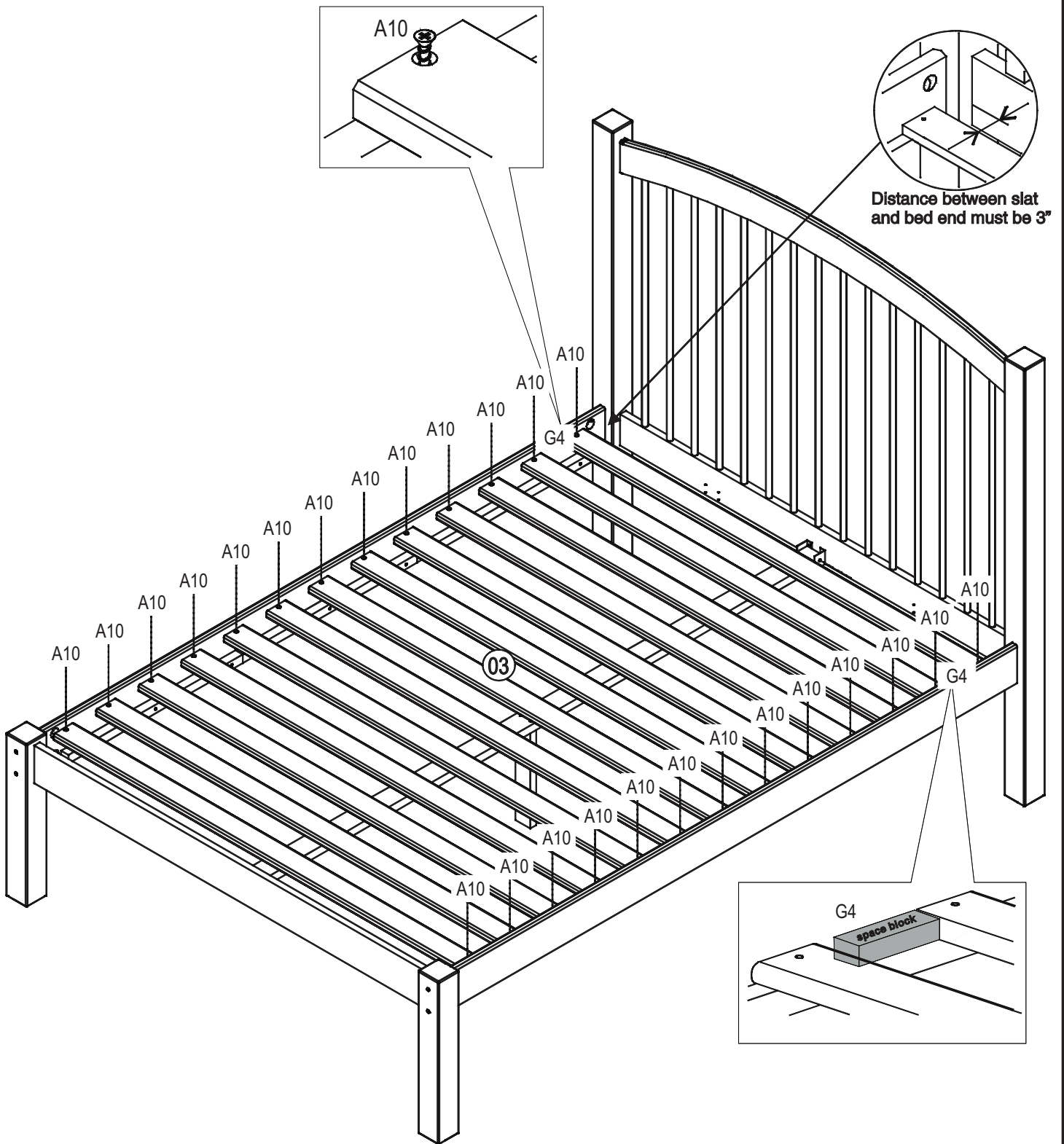

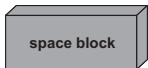
A10	 3,5x30	26
G4	 space block	02